



# HERCULES 5-10-15

impastatrici pizza  
*dough mixers*



**HERCULES 10**  
1. Timer opzionale  
*Optional timer*

- Struttura in acciaio a grosso spessore.
- Verniciatura antigraffio a polveri epossidiche alimentare.
- Vasca con bordo rinforzato e asta rompi pasta in acciaio AISI 304.
- Spirale forgiata.
- Coperchio vasca conforme alle normative.
- Motore potente e ventilato.
- Trasmissione moto interno con catena rinforzata.
- Comandi a bassa tensione resistenti IP 67.
- Disponibile versione con timer a richiesta per i mod. 10-15.

- *Made from large thickness steel.*
- *Scratch resistant powder coating.*
- *Bowl with reinforced edge and AISI 304 S/S shaft.*
- *Forged spiral tool.*
- *Container lid conforms to regulations.*
- *High efficiency ventilated motor.*
- *Reinforced chain drive.*
- *Low voltage IP67 protection rated controls.*
- *On request timer version for mod. 10-15.*



**HERCULES 5**



**HERCULES 15**





2. Coperchio vasca conforme alle normative  
*Container lid conform to regulations*



3. Coperchio sollevabile  
*Liftable lid*



4. Asta rompipasta  
*Shaft*



5. Comandi con timer opzionale  
*Controls with optional timer*

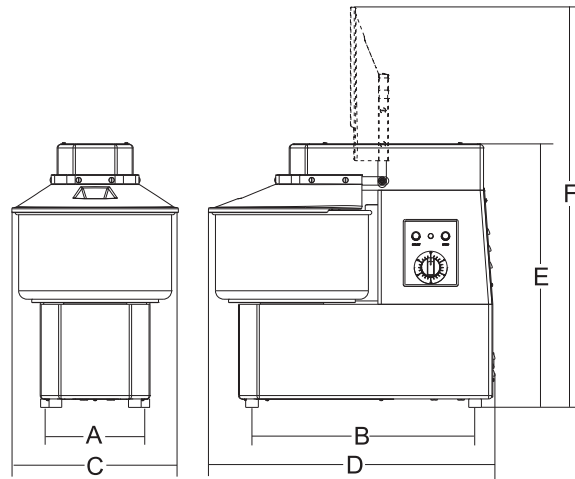

	Potenza Power Spannung Puissance	Alimentazione Power source Betriebsspannung Alimentation	Capacità vasca Tank capacity Becken kapazität Cuve capacité	Capacità impasto Dough capacity Teig kapazität Capacité pâte	Dimensioni vasca Tank dimensions Becken abmessungen Dimensions cuve	A	B	C	D	E	F	Peso netto Net weight Nettogewicht Poids net	Dimensioni imballo Shipping Verpack. abmessungen Dim. emballage	Peso lordo Gross weight Bruttogewicht Poids brut
	watt/Hp		lt	kg	mm	mm	mm	mm	mm	mm	mm	Kg	mm	kg
<b>Hercules 5</b>	370/0,5	230V/50Hz	7	4	Ø 265x140	220	410	280	505	440	670	36	500x630x650	42
<b>Hercules 10</b>	370/0,5	230-380V/50Hz	12	8	Ø 280x190	250	490	305	580	560	825	44	570x720x700	54
<b>Hercules 15</b>	550/0,75	230-380V/50Hz	16	12	Ø 320x200	250	500	340	590	560	850	48	570x720x700	58
	Potencia Potência Мощность 功率	Alimentación Alimentação Питание 电源	Capacidad tina Capacidade recipiente Объем емкости 攪拌箱容積	Capacidad de la pasta Capacidade da massa de pão Тесто нормування 面团容量	Dimensiones cuba Dim.tanque Pacote de espaço 攪拌箱容積	A	B	C	D	E	F	Peso neto Peso bruto Bec netto 净重	Dimensiones embalaje Dimensões embalagem Paakepaak 包裝尺寸	Peso bruto Peso bruto Bec brutto 毛重



# HERCULES 20-30-40-50

impastatrici pizza  
*dough mixers*



## HERCULES

1. Timer opzionale  
*Optional timer*

- Struttura in acciaio C40 a grosso spessore.
- Verniciatura antigraffio a polveri epossidiche alimentare.
- Vasca con bordo rinforzato e asta rompi pasta in acciaio AISI 304.
- Spirale forgiata.
- Coperchio vasca conforme alle normative con foro per aggiunta prodotto in lavorazione.
- Motore potente e ventilato con riduttore a vite senza fine a bagno d'olio.
- Protezione termica motore.
- Trasmissione moto interno con catena rinforzata.
- Comandi a bassa tensione resistenti IP 67.
- Ruote, timer e coperchio griglia opzionali.
- Disponibile a 2 velocità su richiesta.

## VERSIONE TA:

- Testa sollevabile.
- Vasca asportabile.

- Made from large thickness C40 steel.
- Scratch resistant powder coating.
- Bowl with reinforced edge and AISI 304 S/S shaft.
- Forged spiral tool.
- Lid with opening to add ingredients during operation.
- High efficiency ventilated motor with oil-bath gear box.
- Thermal overload protection circuit breaker
- Reinforced chain drive.
- Low voltage IP67 protection rated controls.
- Optionals: wheels, timer and grill cover.
- On request 2 speed version.

## TA VERSION:

- Lifiable head for tank removal and easy clearing.
- Removable container.



HERCULES TA



2. Coperchio griglia e ruote opzionali  
*Optionals grill cover and wheels*

3. Timer opzionale  
*Optional timer*



4. Coperchio con foro per aggiunta prodotto  
*Lid with opening to add ingredients*



5. Testa sollevabile  
*Liftable head*

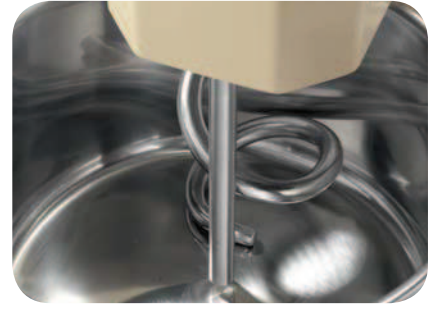

6. Asta rompipasta  
*Shaft*



7. Comandi con timer opzionale  
*Controls with optional timer*



8. Comandi 2V  
*Controls 2V*

**HERCULES**

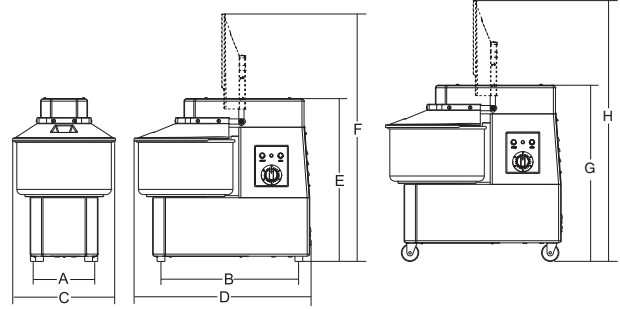

**HERCULES TA**

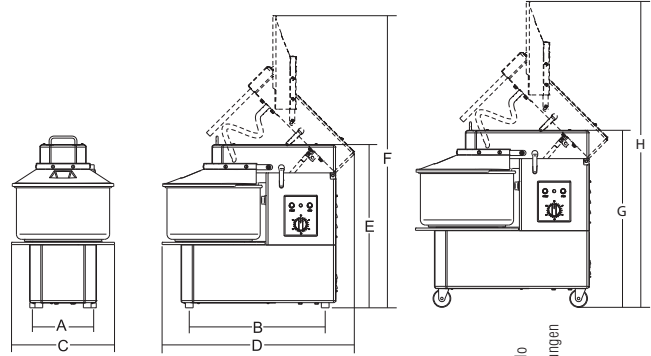

Potenza  
Power  
Spannung  
Puissance

Alimentazione  
Power source  
Betriebsspannung  
Alimentation

Giri vasca - spirale  
Revolutions tank - spiral  
Umdrehungen Becken - Spirale  
Tours cuve - Spirale

Capacità vasca  
Tank capacity  
Becken Kapazität  
Cuvé capacité

Capacità impasto  
Dough capacity  
Teig Kapazität  
Capacité pâte

Dimensioni vasca  
Tank dimensions  
Becken abmessungen  
Dimensions cuve

Peso netto  
Net weight  
Nettogewicht  
Poids net

Dimensioni imballo  
Shipping  
Verpack. abmessungen  
Dim. emballage

Peso lordo  
Gross weight  
Bruttogewicht  
Poids brut

	watt/HP		r.p.m.	lt	kg	mm	mm	mm	mm	mm	mm	mm	mm	Kg	mm	kg	
<b>Hercules 20</b>	750/1	230-400V/50Hz	10 - 85	21	17	360x210	230	530	390	680	625	950	705	1030	65	530x830x1020	75
<b>Hercules 30</b>	1100/1,5	230-400V/50Hz	10 - 85	32	25	400x260	270	590	440	740	700	1050	780	1130	95	530x830x1020	105
<b>Hercules 40</b>	1500/2	230-400V/50Hz	10 - 85	41	35	452x260	310	660	480	825	730	1135	810	1215	105	630x970x1070	115
<b>Hercules 50</b>	1500/2	230-400V/50Hz	10 - 85	52	44	500x270	310	680	540	880	750	1205	830	1285	-	630x970x1070	-
<b>Hercules 20 2V</b>	750-1100/ 1-1,5	230-400V/50Hz	1V=10 - 85 2V=20 - 170	21	17	360x210	230	530	390	680	625	950	705	1030	65	530x830x1020	75
<b>Hercules 30 2V</b>	1300-1700/ 1,8-2,3	230-400V/50Hz	1V=10 - 85 2V=20 - 170	32	25	400x260	270	590	440	740	700	1050	780	1130	95	530x830x1020	105
<b>Hercules 40 2V</b>	1500-2200/ 2-3	230-400V/50Hz	1V=10 - 85 2V=20 - 170	41	35	452x260	310	660	480	825	730	1135	810	1215	105	630x970x1070	115
<b>Hercules 50 2V</b>	1500/2	230-400V/50Hz	1V=10 - 85 2V=20 - 170	52	44	500x270	310	680	540	880	750	1205	830	1285	-	630x970x1070	-
<b>Hercules 20 TA</b>	750/1	230-400V/50Hz	10 - 85	21	17	360x210	230	530	400	751	635	1125	715	1205	88	530x830x1020	98
<b>Hercules 30 TA</b>	1100/1,5	230-400V/50Hz	10 - 85	32	25	400x260	270	590	440	823	710	1260	790	1340	109	530x830x1020	119
<b>Hercules 40 TA</b>	1500/2	230-400V/50Hz	10 - 85	41	35	452x260	310	660	490	910	740	1360	820	1440	125	630x970x1070	135
<b>Hercules 50 TA</b>	1500/2	230-400V/50Hz	10 - 85	52	44	500x270	310	680	540	970	795	1415	875	1495	-	630x970x1070	-

Potencia  
Potência  
Мощность  
功率

Alimentación  
Alimentação  
Питание  
電源

Vueltas tina - espiral  
Gros recipiente - espiral  
Цистернам револуций - спираль  
革命缸克 - 螺旋

Capacidad tina  
Capacidade recipiente  
Объем емкости  
攪拌箱容積

Capacidad de la pasta  
Capacidade da massa de pão  
Тесто по емкости  
面团容量

Dimensiones cuba  
Dim. tanque  
Размеры башины  
攪拌箱容積

Peso neto  
Peso líquido  
Bec netto  
淨重

Dimensiones embalaje  
Dimensões embalagem  
Размеры упаковки  
包裝尺寸

Peso bruto  
Peso bruto  
Bec bruto  
毛重